

97x97x33mm

Model B

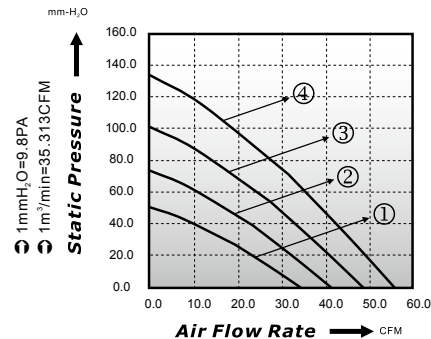

P-Q Curve (At Rated Voltage)



Dimensions Drawing

Unit: (mm)

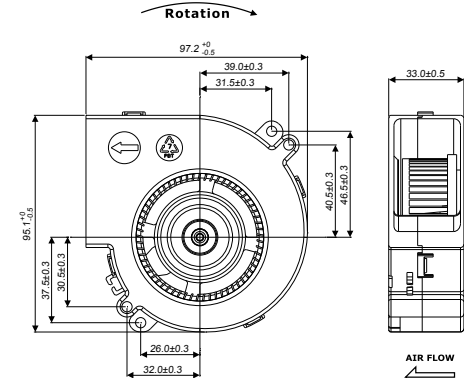

Model No	Bearing (*)	Rated Voltage (VDC)	Rated Current (A)	Power Consumption (Watts)	Speed (rpm)	Air Flow (CFM)	Static Pressure (mmH ₂ O)	Noise (dBA)	Curve
EBD09733-12L*	●	12	1.10	13.20	4800	34.08	50.31	59.0	1
EBD09733-12M*	●	12	1.40	16.80	5200	41.06	73.03	61.0	2
EBD09733-12H*	●	12	1.80	21.60	5700	48.31	101.08	63.0	3
EBD09733-12HH*	●	12	3.40	40.80	6500	55.53	133.54	68.0	4

* Bearing Type: ○ Sleeve ● Two Ball ⊙ Hydro-Dynamic